

ARTU Remote Terminal Unit

Installation & Operation Instruction V1.3

Declaration

All rights reserved. Without the written permission of the Company, the contents of any paragraph or section in this manual shall not be copied, copied or disseminated in any form. Otherwise, all consequences shall be borne by the violator.

Our company reserves all legal rights.

Our company reserves the right to modify the product specifications described in this manual without prior notice. Before placing an order, please consult your local agent for new specifications of this product.

Catalog

1 Overview	1
2 Model instruction	1
3 Product Features	1
4 Use conditions	1
5 Product Specifications	2
5.1 ARTU-K8/K16/K32 Remote signal unit	2
5.1.1 Overview	2
5.1.2 Technical parameters	2
5.1.3 Installation and wiring	2
5.1.4 Communication instructions	5
5.1.5 Communication examples	9
5.2 ARTU-KJ8 Remote signal and remote control combination	10
5.2.1 Overview	10
5.2.2 Technical Parameter	10
5.2.3 Installation and wiring	10
5.2.4 Communication instruction	11
5.2.5 Communication Example	13
5.2 Appendix	14
5.3 Setting of dial code switch	14
5.3.1 Definition of dial code	14
5.3.2 Add setting	14
5.3.3 Baud rate setting	14
5.3.4 Mode setting	14
5.3.5 Format setting	14
5.4 Modbus Function code description	14
5.4.1 Abnormal reply format of ARTU remote terminal unit to command received in error	14
5.4.2 Functional status of 01H/02H using Modbus	15
5.4.3 Read using Modbus's functions of 03 or 04	15
5.4.4 Use the 05H function of Modbus to force the alarm state	15
5.4.5 Use the 06H function of Modbus to write single data	16
5.4.6 Use Modbus's 10H function to write multiple data	16
5.5 Communication wiring method	17
5.6 Debugging and maintenance	18
5.6.1 Use instruction	18
5.6.2 Debugging	18
5.7 Outline and dimension diagram	19
ARTU-K8/K16/K32 Remote signal unit Outline and dimensions	19
ARTU-KJ8 Remote signal & remote control unit Outline and dimensions	19

1 Overview

ARTU remote terminal unit is a high-performance intelligent distribution element, which is applied in intelligent distribution, industrial automation and other fields. Products include: remote control unit, remote signaling unit.

Meet the standards:

JB/T 10388-2002 General technical conditions for intelligent measurement and control node products with bus communication function

GB/T 13729-2002 Remote terminal equipment

2 Model instruction

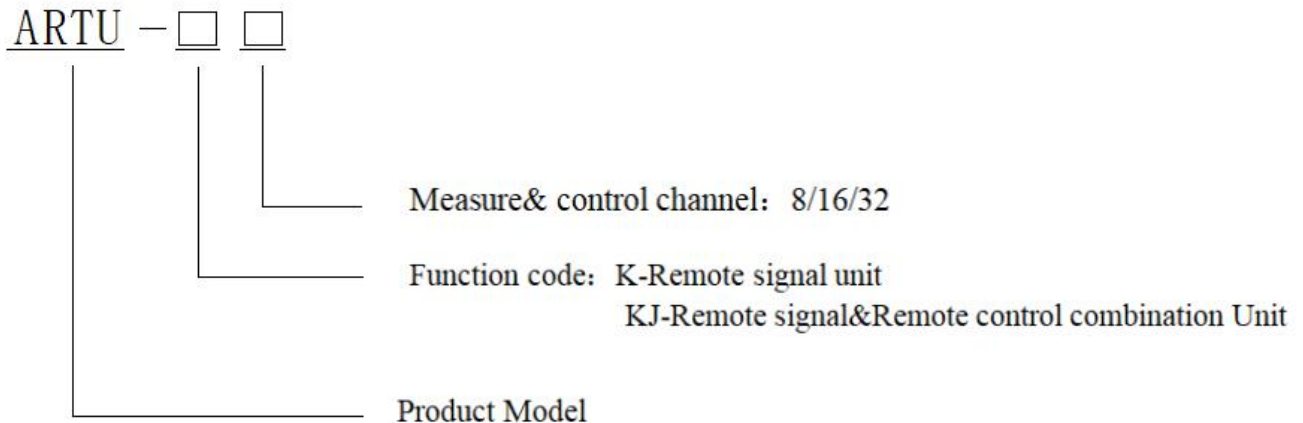

3 Product Features

1) The product has channel status indicator light and communication status indicator light. Among the two communication interfaces, one is used for setting and debugging common parameters, and the other is used for reading and setting "four-remote" values.

2) The address and baud rate of the product can be set by upper computer or local dial code switch.

3) The product adopts software and hardware "watchdog" technology to prevent the phenomenon of crash

4 Use conditions

1) Auxiliary power supply:

24VDC, allowing 18 ~ 36VDC

220VAC (DC) allows AC85 ~ 275V or DC100 ~ 350V, subject to the actual wiring diagram.

2) Power consumption: $\leq 5W$

3) Working environment: $-5 \sim +55^{\circ}C$

4) Relative humidity: $\leq 95\%RH$, non-condensation, non-corrosive gas

5) Storage temperature: $-25 \sim +70^{\circ}C$

6) Altitude: $\leq 2500m$

7) Protection level: IP20

8) Insulation strength:

Conventional: 2kV/1min, 50Hz

Artu-kj8: 1kV/1min between power supply, communication and switching input, 50Hz;

Relay and power // communications // switch between input and 2 kv / 1 min, 50 hz

9) Installation method: TS35 guide rail installation

10) EMC performance meets the following standards:

GB/T 17626.2 Electrostatic discharge immunity test class 4

GB/T 17626.3 Radiofrequency electromagnetic field radiation immunity Test class 3

GB/T 17626.4 Electrical fast transient pulse group immunity Test class 4

GB/T 17626.5 Impact (surge) immunity - Test Class 3 (ARTU-KJ8 test class 1)

GB/T 17626.6 Conducted disturbance immunity test class 3 for rf field induction

GB/T 17626.12 Oscillating wave immunity - Test class 3

5 Product Specifications

5.1 ARTU-K8/K16/K32 Remote signal unit

5.1.1 Overview

ARTU remote signal unit is a switch acquisition unit specially developed for intelligent power distribution, industrial automation and other fields, which is used to acquire switch-volume signals and convert them into digital signals through communication and data exchange of upper computer monitoring system.

5.1.2 Technical parameters

Performance	Indicators
Input circuit	8/16/32
Input mode	Active wet contact (DC12V) or passive dry contact
Bus way	Half duplex RS485 (Modbus RTU), three-core shielding wire is recommended
Bus capacity	≤32
Switch event resolution	The ability to distinguish successive displacement of multiple contacts. When the displacement interval of any two contacts is greater than 1 millisecond, The ability to differentiate units (less than 2ms) is reflected in the SOE
Remote scanning speed	The scanning time of all channels for one week is 1ms
Remote signal debouncing time	All channels adopt a unified debuffing time of 1ms(configurable)
Event sequence logging (SOE) capacity	1600 groups

5.1.3 Installation and wiring

5.1.3.1 Overall dimensions and unit installation

Outline size (length × width × height) : 160 × 50 × 110mm (see Appendix 6.5)

Installation: Standard track TS35

5. 1. 3. 2 Wiring

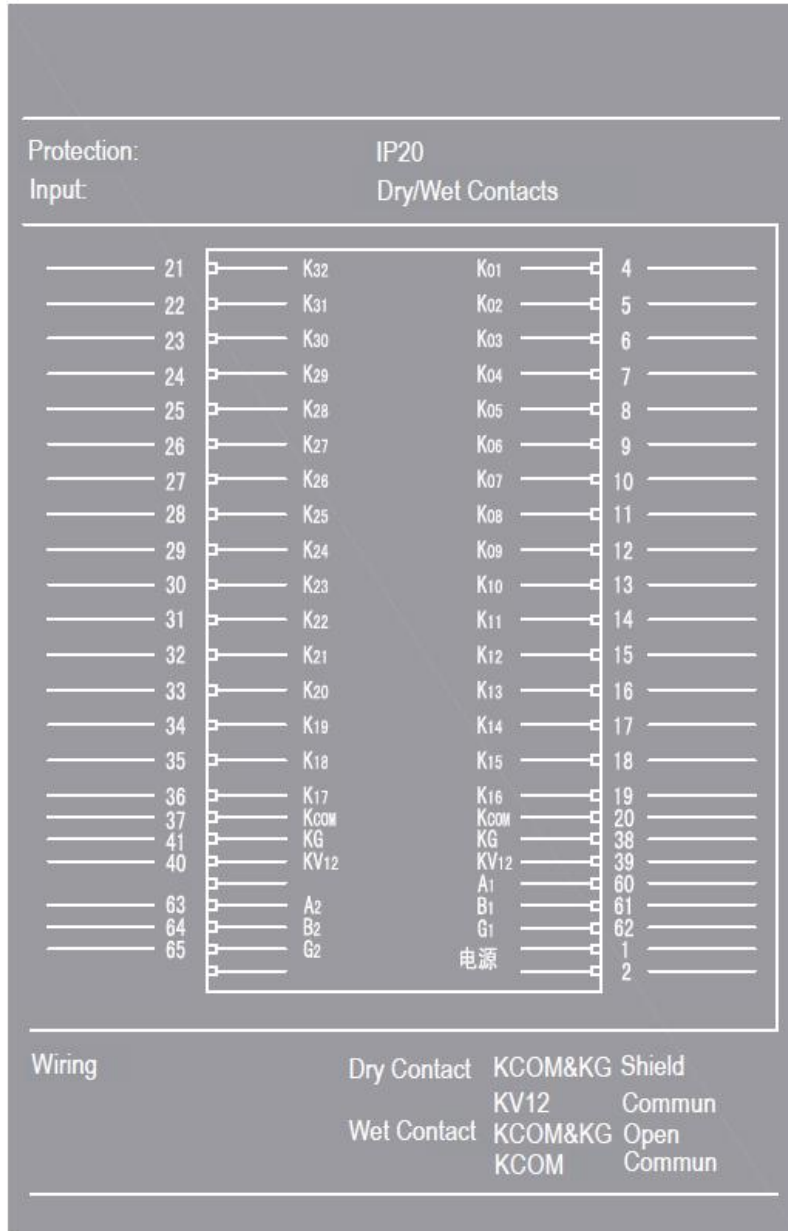

K8/K16 Terminal number

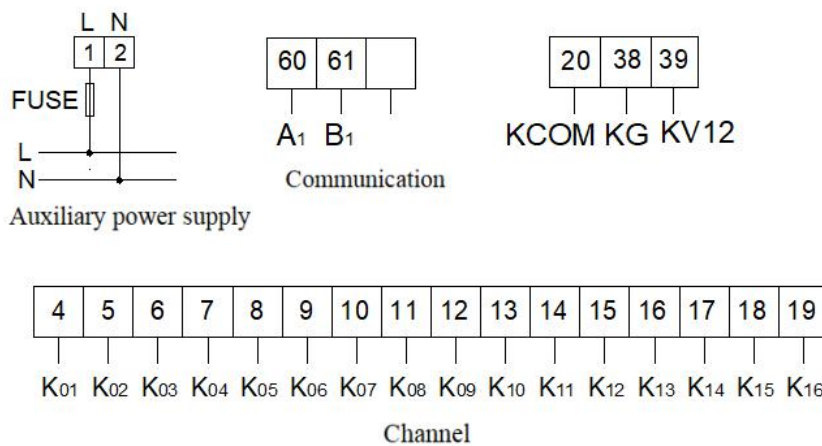

K32 Terminal number

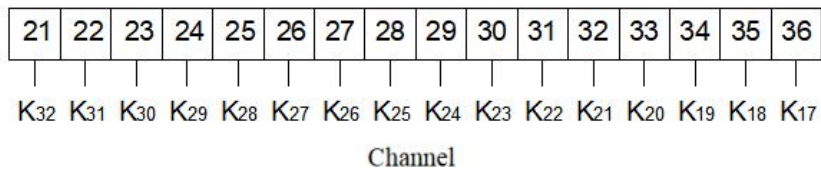
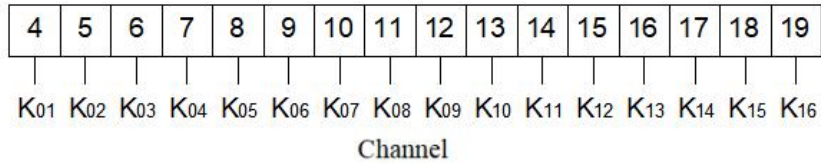
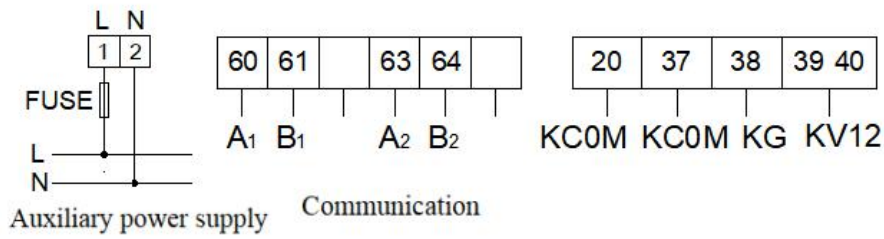

Note:

Active wet contact: K_i ($i = 1 \sim 32$) and common terminal K COM are access terminals of each channel, while KV12 and KG are suspended.

Passive dry contact: K_i ($i = 1 \sim 32$) and common end KV12 are access ends of each channel, while KCOM should be short-connected with KG.

5. 1. 3. 3 Application examples

a) Connecting diagram of passive dry contact:

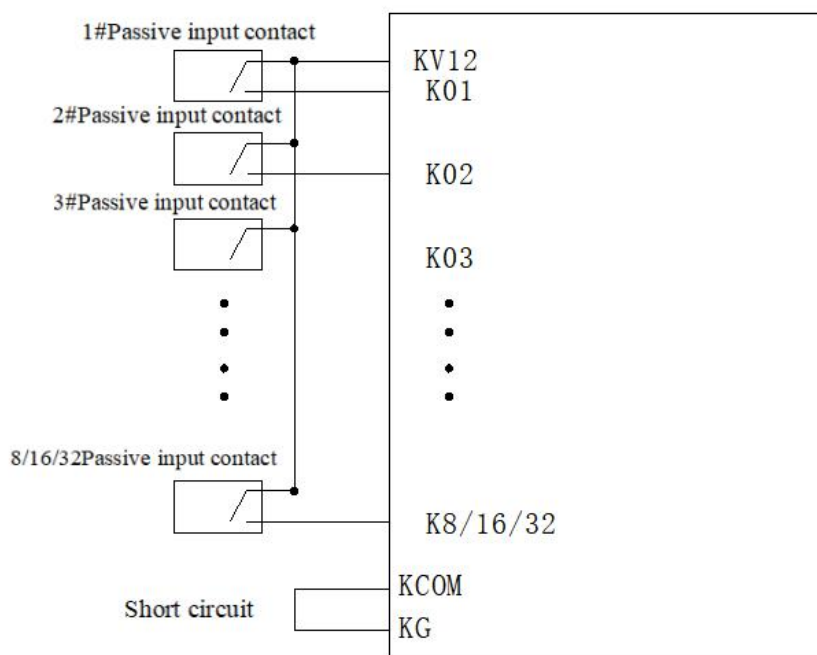

ARTU-K8/16/32

b) Active wet contact connection diagram:

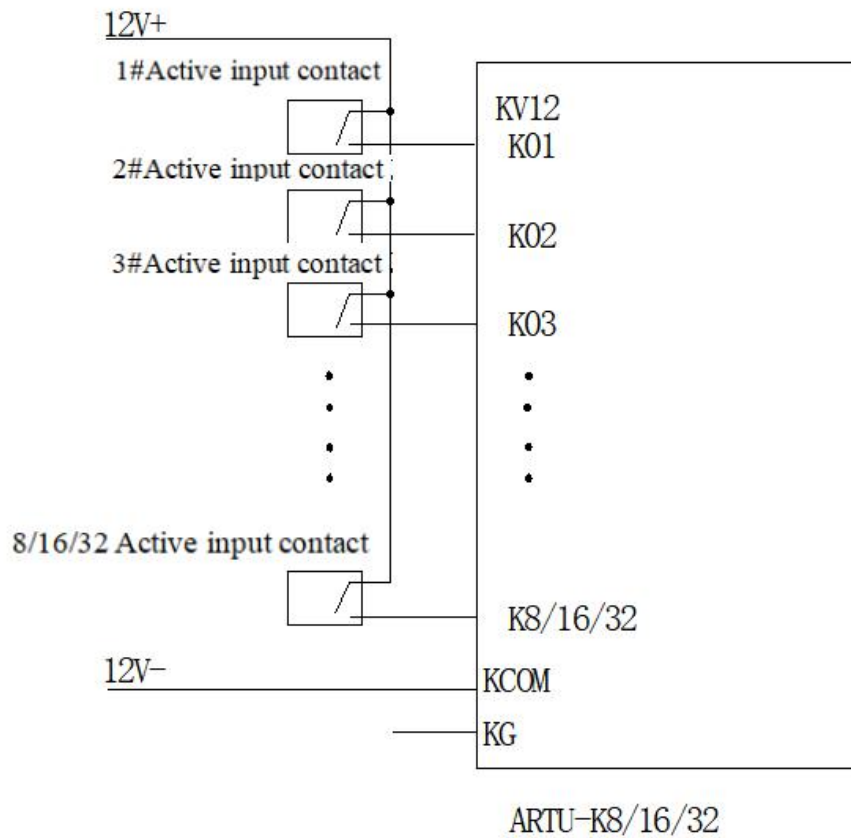

5.1.4 Communication instructions

5.1.4.1 Read and write register contents

Modbus function code 03 (03H) and 04 (04H) can be used to access all contents of the address table, and function code 16 (10H) can be used to write continuous register data.

Data address	Data content	Data types	Read/Write	Command word	Data length(byte)	Write to allow operating ports
00	Meter identification code #	Fixed-point number	R	03、04	2	
01	Version number	Fixed-point number	R	03、04	2	
02	Address number	Fixed-point number	R/W	03、04/16	2	COMM2
03	Communication baud rate	Fixed-point number	R/W	03、04/16	2	COMM2
04	Communication check mode	Fixed-point number	R/W	03、04/16	2	COMM2
05	Clock setting seconds, minutes (BCD code)	Fixed-point number	R/W	03、04/16	2	COMM2
06	Clock setting hours, days (BCD code)	Fixed-point number	R/W	03、04/16	2	COMM2

07	Clock setting month, year (BCD code)	Fixed-point number	R/W	03、04/16	2	COMM2
08	Clock setting allowed (1: YES)	Fixed-point number	R/W	03、04/16	2	COMM2
09	Reserve					
10	Reserve					
11	SOE Address pointer (25-8021)	Fixed-point number	R	03、04	2	
12	Current time millisecond (integer 0-999)	Fixed-point number	R	03、04	2	
13	Current time seconds, minutes (BCD)	Fixed-point number	R	03、04	2	
14	Current time, hour day (BCD)	Fixed-point number	R	03、04	2	
15	Current time month, year (BCD)	Fixed-point number	R	03、04	2	
16	Current state of remote signaling channel (32 ~ 17)	Fixed-point number	R	03、04	2	
17	Current state of remote signaling channel (16 ~ 1)	Fixed-point number	R	03、04	2	
18	Debouncing time of remote signaling channel (1~5000ms)	Fixed-point number	R/W	03、04/16	2	COMM1
19	SOE data reset (1: YES)	Fixed-point number	R/W	03、04/16	2	COMM1
20-24	Reserve	Fixed-point number				
25	(Data 1) Milliseconds (integer)	Fixed-point number	R	03、04	2	
26	(Data 1) Seconds, minutes (BCD code)	Fixed-point number	R	03、04	2	
27	(Data 1) hour, day (BCD code)	Fixed-point number	R	03、04	2	
28	(Data 1) Month, year (BCD code)	Fixed-point number	R	03、04	2	
29	(Data 1) There is an event channel 32-17	Fixed-point number	R	03、04	2	
30	(Data 1) There is an event channel 16-1	Fixed-point number	R	03、04	2	
31	(Data 1) Channel event status 32-17	Fixed-point number	R	03、04	2	
32	(Data 1) Channel event status 16-1	Fixed-point number	R	03、04	2	
.	
.	
.	
.	

12817	(Data n) Ms (integer)	Fixed-point number	R	03、04	2	
12818	(Data n) seconds, minutes (BCD code)	Fixed-point number	R	03、04	2	
12819	(Data n)hour, day (BCD code)	Fixed-point number	R	03、04	2	
12820	(Data n)Month, year (BCD code)	Fixed-point number	R	03、04	2	
12821	(Data n)There is an event channel 32-17	Fixed-point number	R	03、04	2	
12822	(Data n)There is an event channel 16-1	Fixed-point number	R	03、04	2	
12823	(Data n)Channel event status 32-17	Fixed-point number	R	03、04	2	
12824	(Data n)Channel event status 16-1	Fixed-point number	R	03、04	2	

#: Meter identification code: ARTU remote signal unit 201

Note: SOE address from 25 to 12824, total 12,800 *2=25600 bytes;1600 sets of data (each set of data is 16 bytes, it is recommended that users read 16 bytes continuously to avoid reading errors);1600 data loop stores.It is recommended that the user first read the SOE counter, and that the address of the SOE record that recently occurred is the contents of address 11.

Examples:

25	(Data 1) Milliseconds (integer)
26	(Data 1) Second Minutes (BCD code)
27	(Data 1)hour day (BCD code)
28	(Data 1) Month year (BCD code)
29	(Data 1) Channel has events 32-17
30	(Data 1) Channel has events 16-1
31	(Data 1) Channel event status 32-17
32	(Data 1) Channel event status 16-1

Address 25: The millisecond hexadecimal 03 45H event takes place is 837 milliseconds

Address 26: The seconds in which the event occurred (seconds before and after) are 45 minutes and 23 seconds for BCD code 23 45H

Address 27: The time of the event (time after the previous day) BCD code 12 30H is 12 o'clock on the 30th

Address 28: The month year of the incident (month after the year before last) BCD code 07 07H is July 2007

Address 29 and 30: Each bit corresponds to a channel, which corresponds to channel 32-1 in turn. The highest value of address 29 is 1, which means that channel 32 has an event at this time, and 0, which means that no event has occurred in this channel.

Address 31 and 32: If the corresponding bit of address 29 and 30 is 1, it means that an event has occurred in the corresponding channel; if the bit is 1, it means that the channel hops from opening to closing; if the bit of address 29 and 30 is 0, the contents of the corresponding address 31 and 32 have no meaning.

Assume address 29 is 0x0002, address 30 is 0x0004, address 31 is 0x0002, address 32 is 0x0000 means channel 18 hops become closed and channel 3 hops become disconnected.

5. 1. 4. 2 DI reading state :(allow operation port COMM1)

Read the DI state of ARTU remote signal unit with MODBUS command 02

Among which 1=ON, 0=OFF

Data address	Data content	Data type	Read/Write	Command word	Numerical range
0000H	DI1	BIT	R	02	1=ON, 0=OFF
0001H	DI2	BIT	R	02	1=ON, 0=OFF
0002H	DI3	BIT	R	02	1=ON, 0=OFF
0003H	DI4	BIT	R	02	1=ON, 0=OFF
0004H	DI5	BIT	R	02	1=ON, 0=OFF
0005H	DI6	BIT	R	02	1=ON, 0=OFF
0006H	DI7	BIT	R	02	1=ON, 0=OFF
0007H	DI8	BIT	R	02	1=ON, 0=OFF
0008H	DI9	BIT	R	02	1=ON, 0=OFF
0009H	DI10	BIT	R	02	1=ON, 0=OFF
000AH	DI11	BIT	R	02	1=ON, 0=OFF
000BH	DI12	BIT	R	02	1=ON, 0=OFF
000CH	DI13	BIT	R	02	1=ON, 0=OFF
000DH	DI14	BIT	R	02	1=ON, 0=OFF
000EH	DI15	BIT	R	02	1=ON, 0=OFF
000FH	DI16	BIT	R	02	1=ON, 0=OFF
0010H	DI17	BIT	R	02	1=ON, 0=OFF
0011H	DI18	BIT	R	02	1=ON, 0=OFF
0012H	DI19	BIT	R	02	1=ON, 0=OFF
0013H	DI20	BIT	R	02	1=ON, 0=OFF
0014H	DI21	BIT	R	02	1=ON, 0=OFF
0015H	DI22	BIT	R	02	1=ON, 0=OFF
0016H	DI23	BIT	R	02	1=ON, 0=OFF
0017H	DI24	BIT	R	02	1=ON, 0=OFF
0018H	DI25	BIT	R	02	1=ON, 0=OFF
0019H	DI26	BIT	R	02	1=ON, 0=OFF
001AH	DI27	BIT	R	02	1=ON, 0=OFF
001BH	DI28	BIT	R	02	1=ON, 0=OFF
001CH	DI29	BIT	R	02	1=ON, 0=OFF
001DH	DI30	BIT	R	02	1=ON, 0=OFF
001EH	DI31	BIT	R	02	1=ON, 0=OFF
001FH	DI32	BIT	R	02	1=ON, 0=OFF

5. 1. 4. 3 GPS time correction function

The communication is in accordance with the NMEA agreement, and the supporting communication port is COMM2. This unit only USES proofreading for date and time, so \$GPZDA data format is adopted, specifically as follows:

\$GPZDA

Date & Time

Standard time format, day, month, year, local time.

\$--ZDA,hhmmss.sss,xx,xx,xxxx,xx,xx

hhmmss.sss = UTC(Standard time format)

xx = Day, 01 to 31
xx = Month, 01 to 12
xxxx = Year
xx = Local time difference 00 to +/- 13 hours
xx = Local time difference (simultaneous difference)

Examples:

GPS send: \$GPZDA,020102.012,05,11,2007,

To ASC II for: 24 47 50 5A 44 41 2C 30 32 30 31 30 32 2E 30 31 32 2C 30 35 2C 31 31 2C 32 30 30 37 2C

That is, the unit time is set as: November 5, 2007 2:01:02

5. 1. 5 Communication examples

Example 1: Read the current switching state of the remote signaling unit with meter address 2

Send: 0x02,0x03,0x00,0x10,0x00,0x02,0xC5,0xFD

Return: 0x02,0x03,0x04,0x00,0x00,0x00,0x03,0x89,0x32

Description: the first and second channel switches of the remote signaling unit with instrument address 2 are closed, and the remaining 30 channel switches are disconnected.

Example 2: Read 1 to 5 switch states

Send: 0x01,0x02,0x00,0x00,0x00,0x05,0xB8,0x09

Return: 0x01,0x02,0x01,0x10,0xA0,0x44

Description: 0x 10 is converted into a binary number of 00010000, that is, the fifth switch is in a closed state, the others are in an open state.

Example 3: Read the state of 1 to 32 switches

Send: 0x01,0x02,0x00,0x00,0x00,0x20,0x79,0xD2

Return: 0x01,0x02,0x04,0x00,0x00,0x8E,0x04,0x9F,0x81

Description: 0x00,0x00,0x8E,0x04 are converted into binary Numbers of 0000,0000,0000, 1000, 11, 0000,0100, that is, the 18th 19 20 24 27 switch state is closed, the others are open state.

Example 4: Read the state of 17 to 32 switches

Send: 0x01,0x02,0x00,0x10,0x00,0x10,0x78,0x03

Return: 0x01,0x02,0x02,0x8E,0x04,0xDD,0xDB

Description: 0x8E,0x04 are converted into binary number of 1000,1110,0000,0100, that is, the 18th 19, 20, 24, 27 switch state is closed, the others are open state.

Example 5: Set the current time

Send: 0x01,0x10,0x00,0x05,0x00,0x04,0x08,0x12,0x14,0x10,0x21,

0x09,0x07,0x00,0x01,0xA3,0xA8

Return: 0x01,0x10,0x00,0x05,0x00,0x04,0xD1,0xCB

Description: The time is set to 10:14:00 12sec on September 21, 2007 (note the BCD code format).

Example 6: Set the shaking elimination time of remote signaling unit with meter address 1

Send: 0x01,0x10,0x00,0x12,0x00,0x01,0x02,0x00,0x04,0xA4,0xE1

Return: 0x01,0x10,0x00,0x12,0x00,0x01,0xA1,0xCC

Description: shake time set 4 ms (shake elimination time: in the vibration environment, travel switch or button is often because the jitter and signal error, a shaking of the general time is shorter, according to the characteristics of the jitter time is short, can be set up by ARTU remote communication unit to eliminate jitter of the shaking time elimination of reliable signal effectively, so as to achieve the purpose of the anti-interference).

5.2 ARTU-KJ8 Remote signal and remote control combination

5.2.1 Overview

ARTU-KJ8 remote signal and remote control combination unit is a combination unit of switch volume acquisition and remote relay output specially developed for intelligent distribution, industrial automation and other fields, which realizes data exchange with upper computer monitoring system through communication

5.2.2 Technical Parameter

Performance	Indicators	
	Switching input	Relay output
Input/output loop	8	8
Input/output mode	Passive dry contact	8-channel relay output (pulse or hold mode)
Bus way	Half duplex RS485 (Modbus RTU), three-core shielding wire is recommended	Half duplex RS485 (Modbus RTU), three-core shielding wire is recommended
Bus capacity	≤32	≤32
Switch event resolution	The ability to distinguish successive displacement of multiple contacts, with the displacement interval of any two contacts greater than 1 millisecond.	/
Remote scanning speed	The scanning time of all channels for one week is 1ms	/
Remote signal debouncing time	All channels adopt a unified debuffing time of 1ms(configurable)	/

5.2.3 Installation and wiring

5.2.3.1 Installation and outline size

Standard track TS35 (see Appendix)

5.2.3.2 Wiring terminal no.

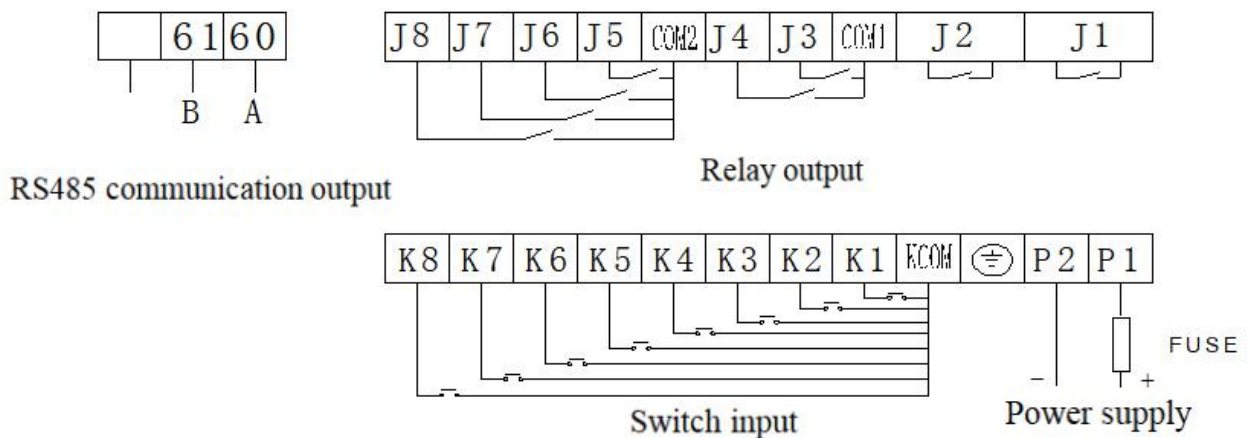

5.2.4 Communication instruction

5.2.4.1 Read-write register contents

Modbus function code 03 (03H) and 04 (04H) can be used to access all contents of the address table, and function code 16 (10H) can be used to write continuous register data.

Data address	Data content	Data type	Read/Write	Command word	Data Length(byte)
00	Meter identification code #	Fixed-point number	R	03、04	2
01	Version	Fixed-point number	R	03、04	2
02	Address(1~247)	Fixed-point number	R/W	03、04/16	2
03	Communication baud rate(38400、19200、9600、4800、2400、1200)	Fixed-point number	R/W	03、04/16	2
04	Communication verification mode (Note 1)	Fixed-point number	R/W	03、04/16	2
05-11	Reserve	Fixed-point number	R	03、04	2
12	Current status of remote control channel (Note 2) High 8-bit DI, low 8-bit DO, Bit0 ~ BIT7 corresponds to DO1 ~ DO8 Bit8 ~ BIT15 corresponds to DI1 ~ DI8	Fixed-point number	R/W		2
13-15	Reserve	Fixed-point number	R	03、04	2
16	Current state of remote signaling channel (Note 2) Bit0 is the first channel of DI1, Bit1 is the second channel of DI2, and so on	Fixed-point number	R	03、04	2
17	Current status of remote control channel (Note 2) Bit0 is the first channel of DO1, Bit1 is the second channel of DO2, and so on	Fixed-point number	R/W	03、04/16	2
18	Remote signal channel debouncing time(1~1000ms)	Fixed-point number	R/W	03、04/16	2
19	Reserve	Fixed-point number	R/W	03、04/16	2
20	Duration of digital output DO1 (Note 3)	Fixed-point number	R/W	03、04/16	2
21	Digital output DO2 duration	Fixed-point number	R/W	03、04/16	2
22	Digital output DO3 duration	Fixed-point number	R/W	03、04/16	2
23	Digital output DO4 duration	Fixed-point number	R/W	03、04/16	2

24	Digital output DO5 duration	Fixed-point number	R/W	03、04/16	2
25	Digital output DO6 duration	Fixed-point number	R/W	03、04/16	2
26	Digital output DO7 duration	Fixed-point number	R/W	03、04/16	2
27	Digital output DO8 duration	Fixed-point number	R/W	03、04/16	2

#: Metre identification code: ARTU-K8J8 is 204 (0xC8)

Note 1 address 04 (Description of communication verification mode) :

0:1 start bit, 8 data bits, 1 stop bit

1:1 start bit, 8 data bits, 2 stop bits

2:1 bit start, 8 bit data, parity, 1 bit stop

3:1 bit start, 8 bit data, odd check, 1 bit stop

Note 2 Current state of channel: 1 is ON for closure and 0 is OFF for disconnection.

Note 3 Duration of digital output: the setting range is 0 ~ 10,000ms, and the factory default is 0ms. You can change the mode of the digital output by setting the output duration. When the duration is 0, it is the ordinary relay mode; When the duration is greater than 0, the digital output is pulse relay mode, and the output duration is the set length of time.

DO state reading:

Read the DO status with MODBUS command 01.

Among which 1=ON, 0=OFF

Data ADD	Data content	Data types	Read/W rite	Comman d word	Numerical range
0000H	DO1	BIT	R	01	1=ON, 0=OFF
0001H	DO2	BIT	R	01	1=ON, 0=OFF
0002H	DO3	BIT	R	01	1=ON, 0=OFF
0003H	DO4	BIT	R	01	1=ON, 0=OFF
0004H	DO5	BIT	R	01	1=ON, 0=OFF
0005H	DO6	BIT	R	01	1=ON, 0=OFF
0006H	DO7	BIT	R	01	1=ON, 0=OFF
0007H	DO8	BIT	R	01	1=ON, 0=OFF

Setting of DO state:

Switch output control is written by MODBUS no. 05 command.

Switch output numeric storage address, each address in the data frame is 1bit storage (1bit).

Write 0XFF00 to ON (close) and 0X0000 to OFF (open), and the other values will not affect DO

Data ADD	Data content	Read/Write	Comman d word	Numerical range
0000H	DO1	W	05	0XFF00=ON, 0X0000=OFF
0001H	DO2	W	05	0XFF00=ON, 0X0000=OFF
0002H	DO3	W	05	0XFF00=ON, 0X0000=OFF
0003H	DO4	W	05	0XFF00=ON, 0X0000=OFF
0004H	DO5	W	05	0XFF00=ON, 0X0000=OFF

0005H	DO6	W	05	0XFF00=ON, 0X0000=OFF
0006H	DO7	W	05	0XFF00=ON, 0X0000=OFF
0007H	DO8	W	05	0XFF00=ON, 0X0000=OFF

Reading DI state :(allow operation port COMM1)

Read DI status with MODBUS command 02.

Among which 1=ON, 0=OFF

Data ADD	Data content	Data types	Read/Write	Command word	Numerical range
0000H	DI1	BIT	R	02	1=ON, 0=OFF
0001H	DI2	BIT	R	02	1=ON, 0=OFF
0002H	DI3	BIT	R	02	1=ON, 0=OFF
0003H	DI4	BIT	R	02	1=ON, 0=OFF
0004H	DI5	BIT	R	02	1=ON, 0=OFF
0005H	DI6	BIT	R	02	1=ON, 0=OFF
0006H	DI7	BIT	R	02	1=ON, 0=OFF
0007H	DI8	BIT	R	02	1=ON, 0=OFF

5.2.5 Communication Example

Example 1: Read the current switching state of the remote signaling unit with meter address 2

Send: 0x02,0x03,0x00,0x0C,0x00,0x01,0x44,0x3A

Return: 0x02,0x03,0x02,0x03,0x00,0xFC,0xB4

Description: the first and second channel switches of the remote signaling unit with instrument address 2 are closed.

Example 2: Read 1 to 5 switch states

Send: 0x01,0x02,0x00,0x00,0x00,0x05,0xB8,0x09

Return: 0x01,0x02,0x01,0x10,0xA0,0x44

Description: 0x10 is converted into a binary number of 00010000, that is, the fifth switch is in the closed state, the others are in the open state.

Example 3: Read relay state 1 to 5

Send: 0x01,0x01,0x00,0x00,0x00,0x05,0xFC,0x09

Return: 0x01,0x01,0x01,0x0C,0x51,0x8D

Description: 0C is converted into binary number of 01100, that is, the relay in the 3rd and 4th channels is in closed state, the other 3 channels are in open state, and the high 3 bits are filled with 0, which does not represent any meaning.

Example 4: Closing the first relay

Send: 0x01,0x05,0x00,0x00,0xFF,0x00,0x8C,0x3A

Return: 0x01,0x05,0x00,0x00,0xFF,0x00,0x8C,0x3A

Example 5: Set the relay of the first line as the pulse output of 3 seconds, that is, the communication control will automatically disconnect after 3 seconds of closure

Send: 0x01,0x10,0x00,0x14,0x00,0x01,0x02,0x0B,0xB8,0xA2,0x06

Return: 0x01,0x10,0x00,0x14,0x00,0x01,0x41,0xCD

5.2 Appendix

5.3 Setting of dial code switch

5.3.1 Definition of dial code

1	2	3	4	5	6	7	8	9	10
Address setting					Baudrate setting		Mode setting	Communication mode	
1 0 0 0 0					0 0		0	0 0	

5.3.2 Add setting

Dial code1	Dial code2	Dial code3	Dial code4	Dial code5	Add
1	0	0	0	0	1
0	1	0	0	0	2

1	1	1	1	1	31
0	0	0	0	0	32

5.3.3 Baud rate setting

Baudrate	Dial code 6	Dial code 7
9600bps	0	0
4800bps	1	0
38400bps	0	1
19200bps	1	1

5.3.4 Mode setting

	Dial code 8	Note: Dial code 8 and reset the address or baud rate to work in the new communication mod
Meter local setting address, baud rate	0	
Host computer sets the address and baud rate	1	

5.3.5 Format setting

Mode	Dial code9	Dial code10
10 bits: 1 start bit, 8 data bits, 1 stop bit	0	0
11 bits: 1 bit start, 8 bits data, 2 bits stop (reserved)	1	0
11 bits: 1 bit start, 8 bit data, parity, 1 bit stop	0	1
11 bits: 1 bit start, 8 bit data, odd check, 1 bit stop	1	1

Note: Dial code switch status description: 1: OFF, 0: ON

5.4 Modbus Function code description

5.4.1 Abnormal reply format of ARTU remote terminal unit to command received in error

ARTU remote terminal unit communication exception code reply format			
Add	Corresponding error function	Exception error code data	CRC check
BYTE	BYTE	BYTE	WORD
XX	XX (requested function code +80H)	01H、02H、03H、04H	XXXX (CRC check value)

The exception code is defined as follows:

- 01 Illegal function codes (received function codes are not supported);
- 02 Invalid data location (specified data location is beyond the scope of the meter);
- 03 Invalid data value (received data value sent to the host is beyond the data range of the corresponding address).
- 04 Equipment failure from the station (the data value received to the host is not currently allowed to be written)

5. 4. 2 Functional status of 01H/02H using Modbus

Upper computer required reading (01H/02H function of MODBUS)				
ADD	Description	ADD	Data	CRC check
BYTE	BYTE	WORD	WORD	WORD
XX	XX(01H/02H)	XXXX	XXXX	XXXX(CRC check value)

Lower device reply(MODBUS function 01/02)				
ADD	Function	Data length	Data	CRC check
BYTE	BYTE	BYTE	N BYTE	WORD
XX	XX(01H/02H)	XX	XXXX.....	XXXX(CRC check value)

Abnormal Lower device reply (MODBUS function of 81H/82H)				
ADD	Corresponding error function	Exception error code data		CRC check
BYTE	BYTE	BYTE		WORD
XX	XX(81H/82H)	XX (02H wrong address, 03H wrong data)		XXXX(CRC check value)

5. 4. 3 Read using Modbus's functions of 03 or 04

Upper computer required reading (03H/04H function of MODBUS)				
ADD	Function	Start address	Data	CRC check
BYTE	BYTE	WORD	WORD	WORD
XX	XX(03H/04H)	XXXX	XXXX(N)	XXXX(CRC check value)

Lower device reply (03H/04H function of MODBUS)				
ADD	Function	Data length	Data	CRC check
BYTE	BYTE	BYTE	2*N BYTE	WORD
XX	XX(03H/04H)	XX(2*N)	XXXX.....	XXXX(CRC check value)

Abnormal Lower device reply(MODBUS 83H/84H function)				
ADD	corresponding error function	Exception error code data		CRC check
BYTE	BYTE	BYTE		WORD
XX	XX(83H/84H)	XX (02H wrong address, 03H wrong data)		XXXX(CRC check value)

5. 4. 4 Use the 05H function of Modbus to force the alarm state

Upper computer required reading (05H function of MODBUS)				
ADD	Function	ADD	Data	CRC check
BYTE	BYTE	WORD	WORD	WORD

XX	XX(05H)	XXXX	0ff00H 或 0000H	XXXX(CRC check value)
----	---------	------	----------------	------------------------

Lower device reply(MODBUS 05 functions)				
ADD	Function	ADD	Data	CRC check
BYTE	BYTE	WORD	WORD	WORD
XX	XX(05H)	XXXX(same as the upper computer request)	XXXX(same as the upper computer request)	XXXX(CRC check value)

Abnormal Lower device reply(MODBUS 08 functions)			
ADD	corresponding error function	Exception error code data	CRC check
BYTE	BYTE	BYTE	WORD
XX	XX(85H)	XX(Wrong address for 02H, wrong data for 03H)	XXXX(CRC check value)

5. 4. 5 Use the 06H function of Modbus to write single data

Upper computer requires to write a single data (MODBUS's 06H function)				
ADD	Function	Start address	Data	CRC check
BYTE	BYTE	WORD	WORD	WORD
XX	XX(06H)	XXXX	XXXX	XXXX(CRC check value)

Abnormal Lower device reply(MODBUS 06H function)				
ADD	Function	Start address	Data	CRC check
BYTE	BYTE	WORD	WORD	WORD
XX	XX(06H)	XXXX	XXXX	XXXX(CRC check value)

Abnormal Lower device reply(MODBUS 86H function)			
ADD	corresponding error function	Exception error code data	CRC check
BYTE	BYTE	BYTE	WORD
XX	XX(86H)	XX (02H address wrong, 03H data wrong, 04 not allowed to write)	XXXX(CRC check value)

5. 4. 6 Use Modbus's 10H function to write multiple data

Host computer requires to write multiple data (MODBUS's 16 (10H) function)						
ADD	Function	Start address	Data number	Data length	Data	CRC check
BYTE	BYTE	WORD	WORD	BYTE	2*N BYTE	WORD
XX	XX (10H)	XXXX	XXXX(n)	XX(2*n)	XXXX.....	XXXX(CRC check value)

Lower device reply(MODBUS's 16 (10H) functions)				
ADD	Function	Start address	Data number	CRC check
BYTE	BYTE	WORD	WORD	WORD

XX	XX(10H)	XXXX	XXXX	XXXX(CRC check value)
----	---------	------	------	------------------------

Abnormal Lower device reply(90H function of MODBUS)			
ADD	Corresponding error function	Exception error code data	CRC check
BYTE	BYTE	BYTE	WORD
XX	XX(90H)	XX (02H address wrong, 03H data wrong, 04 not allowed to write)	XXXX(CRC check value)

5.5 Communication wiring method

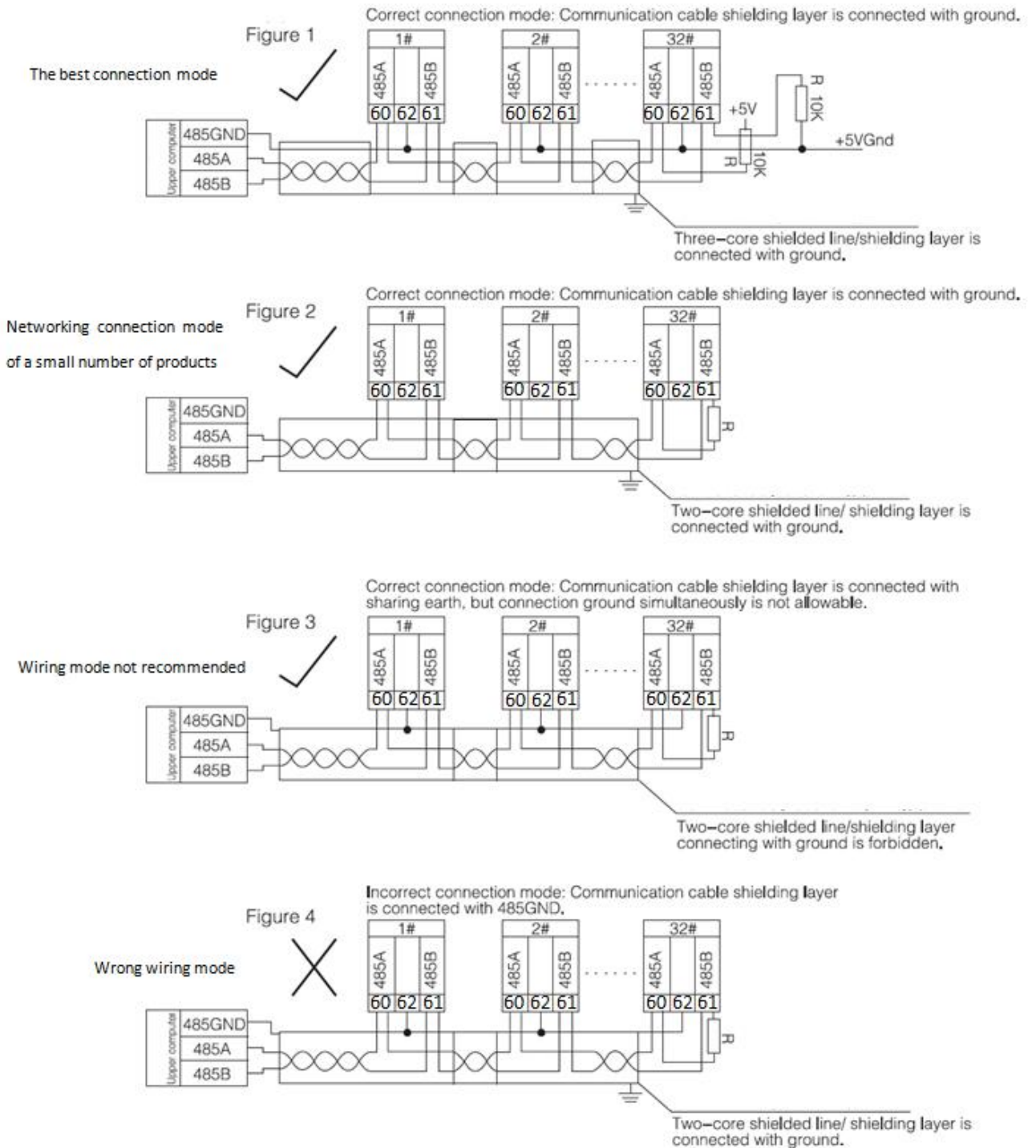

Note: Figure 1 is the best wiring method

Figure 2 is wiring method of few products

Figure 3 wiring method is not recommended

Figure 4 is incorrect wiring method

When multiple ARTU network use, the last of the RS485 should A and B on the terminal and A terminal matching resistance R, impedance matching, to ensure the communication terminal matching resistance generally between 120 Ω - 10 k, wiring terminal matching different resistance may be different. The above diagram shows the use of a three-core shield wire, with the shield layer connected to the ground and G1 terminals of each device connected.

5. 6 Debugging and maintenance

5. 6. 1 Use instruction

- 1) Check whether the power cord is properly connected before power on.
- 2) After the POWER is switched on, the POWER indicator will be on and the RUN will start flashing at the same time. The interval is 1 second.
- 3) Establishment of communication
 - a) Correctly access RS485 bus and connect to the upper computer.
 - b) The upper computer issues commands according to the station number and baud rate of the module and in the format of the protocol. At this point, the module's communication indicator flashes, indicating that the module has received the command from the upper computer and responded, that is, the communication has been established.

5. 6. 2 Debugging

- 1) Check whether the power supply is connected correctly before power on.
 - 2) After power on, observe whether the power lamp is on. If it is not on, it indicates that the power has not been added.
 - 3) Observe whether the running light flashes. If not, it indicates that the module does not operate normally.
 - 4) Communication is established only when the communication indicator flashes.
- Set the upper computer query time interval. Since the bus is half duplex, the upper computer should set an appropriate time interval, which should be determined according to the length and baud rate of module response command. Improper setting of time interval will lead to communication failure

5.7 Outline and dimension diagram

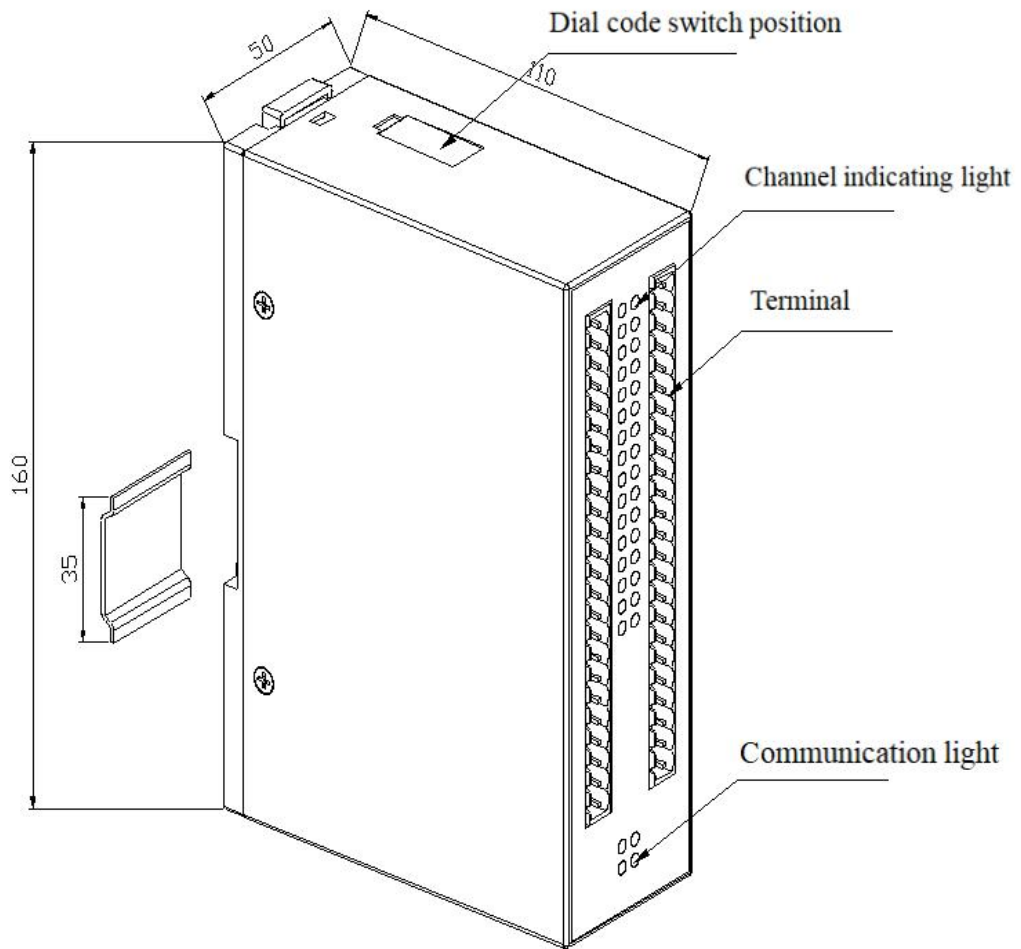

ARTU-K8/K16/K32 Remote signal unit Outline and dimensions

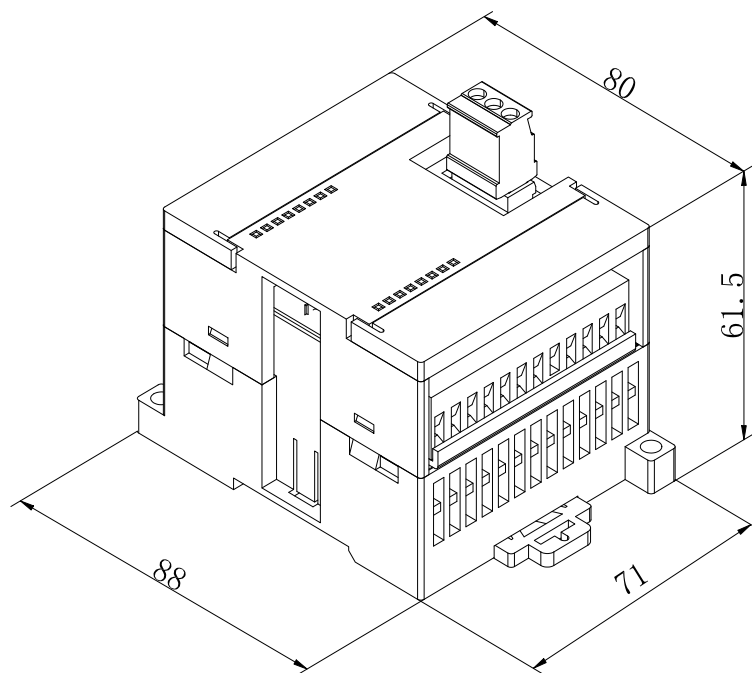

ARTU-KJ8 Remote signal & remote control unit Outline and dimensions